

CAT Fusion 3 Stage Handling Arm

WEIGHT 560kg
CAPACITY See Chart

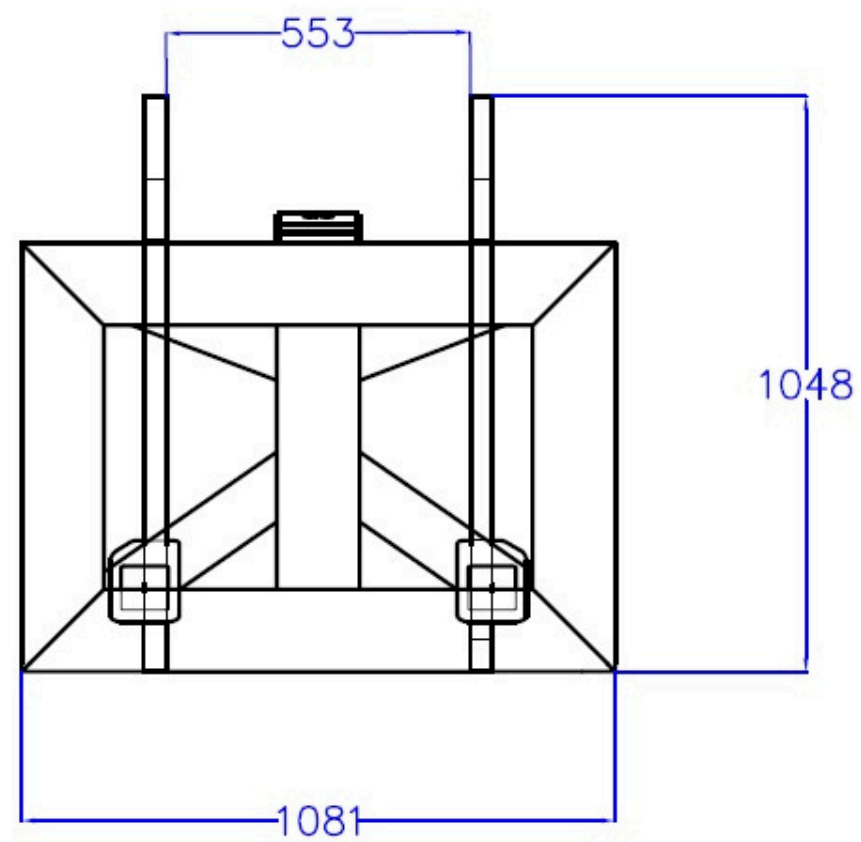

Position	1	2	3	4	5	6	7	8	9
(mm)	2253	2620	2987	3354	3567	3997	4364	4731	4943
(kg)	3500	3090	2680	2272	2034	1555	1145	736	500

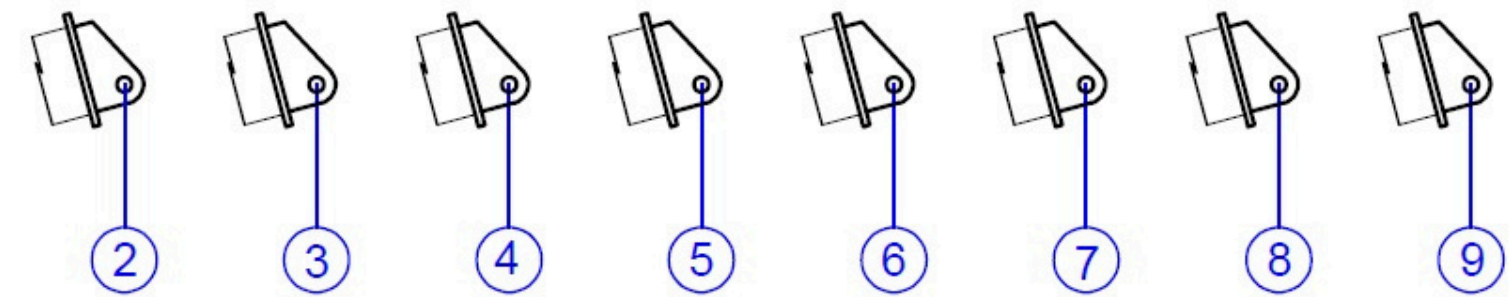
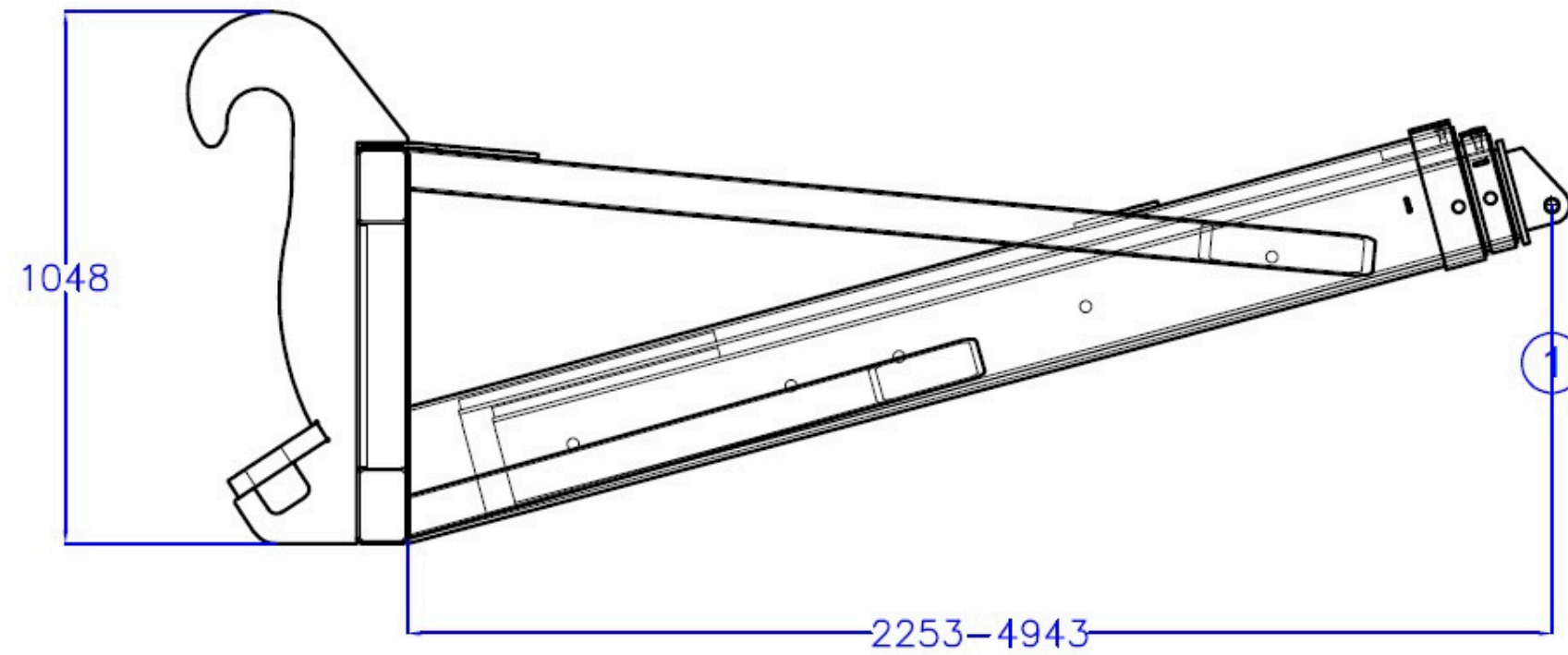